

Your High Definition Picture

Optimizing Your HDTV Picture

The final step is tailoring your cable box to the capabilities of your HDTV using the On Screen Menu. This allows the cable box to automatically optimize both Standard and High-Definition video, based on your HDTV and personal preferences.

Sample Settings Only

To access the On Screen Menu, power ON your HDTV and power OFF the cable box. Press the MENU button on either your remote control or the cable box front panel to call up the On Screen Display.* You may use either the cable box front panel or the remote control to navigate the display:

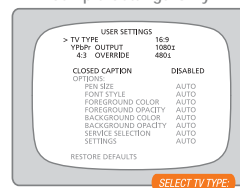

- The arrow on the left indicates the position of the cursor.
- Press the ▲ and ▼ buttons to select the setting you wish to change.
- Press the ► button to select an option for that setting.
- To exit the setting and move to another setting, use the ▲ and ▼ buttons.
- Press the POWER or MENU button to exit the menu and save your settings.

TV TYPE

The first user setting is TV TYPE. Your selection tells the cable box what type of TV you have and how you prefer to watch widescreen programming. Your choices are 16:9, 4:3 Letterbox, or 4:3 Pan Scan.

- Choose 16:9 if you have a widescreen HDTV.
- Choose 4:3 Letterbox if you have a standard TV and you prefer to watch widescreen programming in its original aspect ratio.
- Choose 4:3 Pan Scan if you have a standard screen TV and you prefer that widescreen programming is cropped to fill your screen. Think of this last choice as watching a theater-style movie that has been reformatted to fit your standard screen TV.

Y Pb Pr OUTPUT

Next, use the down arrow to select Y Pb Pr OUTPUT. This setting indicates the picture resolution you prefer when watching High Definition programming. The choices, listed in order of highest to lowest picture resolution, are 1080i, 720p, 480p, and 480i. Your selection will depend on which format(s) your HDTV supports. To maximize your high-definition viewing experience, refer to your television set owner's manual, and use the right arrow button to choose the setting that indicates the highest picture resolution that your television will support.

4:3 OVERRIDE

Finally, use the down button arrow to select 4:3 OVERRIDE. By selecting 480i or 480p you are telling the cable box to send Standard Definition programming to your TV in its original broadcast format. Select OFF and the cable box will default to the resolution selected in the Y Pb Pr OUTPUT setting above. To exit and save changes press the POWER or MENU button.

DVR Installation

For more details on configuring your cable box output settings, including setting Closed Caption preferences, see the Motorola cable box User Guide or visit www.motorola.com/Broadband.

* If the On Screen Menu does not appear on your HDTV screen, your TV may not support the default, standard definition setting (480i). Use the cable box front panel LED to view and change your settings.

Connecting A Stereo TV or HDTV

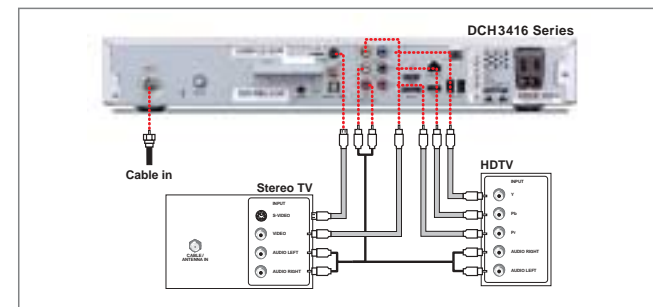

- Step 1: Connect an RF coaxial cable to the cable wall outlet and the CABLE IN connector on the DCH*.
- Step 2: Connect the stereo audio cable to the AUDIO R and L connectors on the DCH* and the AUDIO LEFT and AUDIO RIGHT connectors on the stereo TV. Connect a video cable to the VIDEO OUT connector on the DCH* and the INPUT VIDEO on the TV or an S-video cable to the S-VIDEO connectors on the DCH* and the TV.
- Step 3: For HDTV, connect the box to TV using component video cables.

Important Note: The Time Warner Cable HD/DVR combo receiver will also be able to receive HD programming.* You must have an HD capable television to receive HD programming.

****THE DVR DEFAULT PIN NUMBER IS 0000 or 1234****

If you or the installer change the PIN number, please note the new number in the boxes below.

DVR PIN #

* HD service not available in all areas. Subscription required on some HD services.

Troubleshooting

Troubleshooting

Problem	Possible Solution
Set-top will not power on.	The set-top may have received a software update and may not power on while the new software is being installed. Try again in a few minutes. Verify that the AC power cord is connected to the set-top and an AC outlet. Unplug the set-top from the AC outlet, plug it back in, and then press the POWER button. If the set-top is connected to a switched outlet on another unit, verify that that unit is powered on. Unplug the power cord from the set-top's AC outlet, plug it back in, and then press the POWER button. Press the POWER button on the set-top front panel instead of the remote control. The batteries in the remote control may be depleted.
Remote control does not work.	Verify that the remote control is in "Cable" mode. Verify that there are no obstructions between the remote control and the set-top. Aim the remote control directly at the set-top front panel, not the TV or VCR. The angle between the remote control and the set-top may be too large. Stand in front of the set-top and not too far to either side. Press and release operation keys one at a time, firmly and deliberately. Try changing channels using the buttons on the set-top front panel. Check the batteries in the remote control. Install new batteries if needed.
No audio when viewing cable channels.	Verify that the MUTE button on the set-top or the remote control has not been pressed. Press MUTE on the remote control to restore sound. If the set-top audio output is connected to the TV, verify that the Mute button on the TV has not been pressed. If the set-top audio output is connected to a home theater receiver, verify that the receiver is set to the appropriate input source and the MUTE button on the receiver has not been pressed. Verify that you have the correct cables for the audio ports. Verify that the audio cables are firmly connected between the set-top and the TV, VCR, or home theater receiver.
No audio from center and/or surround speakers of home theater receiver connected to set-top.	Not all Dolby Digital programs feature full 5.1 surround sound. In some cases, the programs may only contain left and right stereo audio. Verify that the S/PDIF cable (coaxial or optical) is firmly connected to the set-top and the home theater receiver. Verify that the home theater receiver is set to a surround sound audio mode (Dolby Digital, Dolby Pro Logic [®] , or Dolby Pro Logic II.) Verify that the receiver is properly configured to work with all connected speakers.
There is no video on the TV screen.	Verify that the TV is powered on and set to the appropriate input source for the set-top. Verify that the set-top is powered on and tuned to an authorized cable channel. Verify that the coaxial cable is firmly connected to the set-top and the wall jack. Verify that all video cables between the set-top and the TV are firmly connected. If the set-top video output is connected to a home theater unit, verify that the home theater unit is powered on and set to the appropriate input source. Not all HDTVs can display every output format (1080i, 720p, 480p, or 480i) available on the DCH3400 Series set-top. To select a different format, follow the directions for "Optimizing Your HDTV Picture" in this brochure.

We're here to assist you, 24 hours a day, 7 days a week.

Customer Care: 1-888-TW-CABLE

On the Web: www.timewarnercable.com/socal

CABLE

HIGH-SPEED ONLINE

DIGITAL PHONE

7082

MOTCombo 5161 7/07



User Guide

Motorola
DVR/HDTV



Using The DVR Remote Control

The **SETUP** Key is used when programming the Remote (e.g. Device Set-Up).

The **DEVICE KEYS** allow you to select which device to setup and operate.

Press **GUIDE** to display all the available programs to view.

Press **DAY +/-** to move forward and back 24 hrs in the Interactive Program Guide.

The **FOUR-WAY CURSOR** Keys allow you to navigate through the on-screen menus.

The **MUTE** Key turns the volume off and back on.

Press **FUNCTION KEYS** for Help, On Demand or Music.

Press **REPLAY** Key to replay the previous few seconds of a program.

Press **LIST** Key to display a list of programs that have been DVR/PVR recorded.

Press **LIVE** Key to display live TV programming.

PICTURE IN PICTURE (PIP)* On/Off feature for Digital SA Boxes only.

Press **SWAP** Key to switch back and forth between the two tuners.

Press **VIDEO SOURCE** Key (also known as BYPASS) to change TV inputs.

Press the **POWER** Key to turn ON/OFF the selected device. This key is also programmable to turn ON/OFF all of your devices with a single key press.

Press **SETTINGS** to access various Set-Top Box options.

Press **INFO** to display additional information about the program you selected.

Press **OK/SELECT** to choose options from the MENU or programs from the GUIDE.

Use the **PAGE +/-** Keys to page up or down while in the GUIDE.

Press **EXIT** to return to watch a program when exploring the GUIDE or MENU.

A, B, or C Keys access features for Digital SA Boxes only.

Press **FAV** to cycle through the favorite channels you have stored in your Set-Top Box.

Press **LAST** to return to the last previously watched channel, or go back one page while in the MENU or GUIDE.

Press **DVR/VOD/VCR CONTROL** Keys to control your DVR or selected VOD events. These same functions are also used to control the VCR or DVD.

Press **HD/ZOOM** Key to change the aspect ratio of your HD television.

Press **CH +/-** to change the channels in the PIP Window.

Press **MOVE*** to change the location of the PIP Window when active.

Actual remote may vary by service area.
* Feature not available in some areas.

Using The Digital Video Recorder

How To Control Live TV

Press **PAUSE** to pause live TV for up to 90 minutes.*

Press **PLAY** to start watching again.

Press **REWIND** or **FAST FORWARD** up to four times to rewind or fast forward at different speeds.

Press **STOP** to jump back to live TV.

Press **REPLAY** to see an instant replay.

Press **SWAP** to switch between 2 programs and preserve the automatic Live TV recording for each. If you change channels without using Swap, you will lose the automatic Live TV recording for the previously watched channel.



Indicates when you first tuned to the channel
Current position in viewing the program
Black section indicates the remaining part of the program

Press **RECORD** to start recording the current program and save it to the Personal Video Library.

The DVR will automatically record up to one hour of live TV, beginning from the point when you tune to a channel. This feature allows you to pause and rewind live TV.

* Pause capacity depends on video format; less than 15 minutes for High Definition programming.

How To Record From Listings

Select your Scheduled Recording in the listings, it will be indicated by the red dot in the Instant Info.

Press **OK** or **INFO** and select the **RECORD** icon to change your options or delete the Scheduled Recording.

From here, select **STOP** icon to cancel the recording, or select **RECORD** icon to see all the Recording Options.



How To Record Using The Interactive Program Guide

Press **GUIDE** to display the Interactive Program Guide.

Use the **FOUR-WAY CURSOR** to highlight the program you want to record. Press **RECORD** to get the information screen. Highlight the **RECORD** and press **RECORD** to record the program at the time it is scheduled.



How To Record All Season Long

Press **GUIDE** to display the Interactive Program Guide and highlight the show you want to record. Press the **RECORD** button and select the **RECORD** action icon.

Select the 'Create a Series Recording' icon.

Select the episode type to record, such as "first run only" or "all episodes". Specify how many recordings to save and how long to save the recording.



For more information and a complete user's guide, go to www.twc.com under the Product User Guides tab.

How To Verify Your Show Is Recording

Just look for the red light or REC displayed on the front of your cable box. When you tune away from the Program Guide, you will also get a message giving you the option to stop or continue the recording.



The record indicator (red dot) will appear next to the program name in the listing and in the information screen.

How To Stop A Recording

Start by pressing **STOP**. The screen will display several options. Use the **FOUR-WAY CURSOR** to highlight the desired action and press **RECORD**.

How To Watch Your Recorded Shows

From the Main Menu, select **DVR**, then select 'My Recordings'. Use the **LEFT** and **RIGHT** buttons to find the program you want to watch.



Press **PLAY** or **REWIND** to select the program.

From the information screen, select the 'Play' icon to resume play from where you left off or select the 'Rewind' icon to restart from the beginning.

Delete Or Modify Your Recorded Programming

To delete a recording, go to the recorded program's Information screen and select the 'X' icon.

For additional options, such as deleting the recording when space is needed, select the '!' icon to modify the 'Delete Priority' setting.

DVR equipment shown is for representation only. Actual equipment may vary. DVR service fee required with DVR equipment for DVR service. To record HD programs, an HD television (not provided) is required.

